

## Labeling and Purification of 12 Genomic DNA Samples Using the NimbleGen Dual-Color DNA Labeling Kit

### Required Equipment

- **ArrayPrep® Target Preparation System**, 115v/230v. (SciGene #2000-00-1/2000-00-2)
- **Centrifuge** with swing out rotor for 96 well microplates
- P10, P20, P200, P1000 pipettes

### Labware Needed

- 1x **50 µl tips** (SciGene #2000-80-1)
- 5x **250 µl tips** (SciGene #2000-80-0)
- 3x **96-well PCR Plates** (SciGene #2000-81-0)
- **V-Groove Reservoir** (SciGene #2000-82-1)
- **U-Bottom 96-well Plate** (SciGene #2000-81-3)
- **Deepwell Plate** (SciGene #2000-82-2)
- **ArrayPrep® PCR Plate Sealer** (SciGene #2000-81-1) – 2 films
- **ArrayPrep® Sealing Film Roller** (SciGene #2000-81-2)
- **96-well Magnetic Ring Stand** (Applied Biosystems #AM10050)
- **Container** for used tips (FisherScientific #03-484-21) or similar

### Reagents Needed

- **NimbleGen Dual-Color DNA Labeling Kit** (NimbleGen #05 223 547 001)
- **ArrayPrep® Magnetic Bead Wash Buffer I**, 50 ml (SciGene #2000-11-1)
- **ArrayPrep® Magnetic Bead Elution Buffer I**, 50 ml (SciGene #2000-12-1)
- **2-Mercaptoethanol** (FisherScientific #BP176-100)
- **Agencourt® AMPure® Magnetic Beads** (Agencourt #A50850, A29152 or A29153)
- **100% Ethanol** (Sigma-Aldrich #E7023-500ML)
- **10 mM Tris-HCl, pH 8.0, 1 mM EDTA (1x TE)** (FisherScientific #BP2473-1)
- **100 mM Tris-HCl, pH 7.6, 10 mM EDTA (10x TE)** (FisherScientific #BP2475-1)
- **5mM EDTA, pH 8.0**, (FisherScientific #BP2482-100, 0.5M stock). Dilute 1:100 with nuclease-free water before use.
- **Nuclease-free water** (FisherScientific #BP2470-1)

### DNA Preparation

For each labeling reaction, use 1 µg of high quality genomic DNA fragmented to a size range of 500 to 2,000 bp in 40.0 µl TE.

- If DNA is in TE Buffer, add TE Buffer, to a final volume of 40.0 µl (10 mM Tris-HCl, pH 8.0, 1 mM EDTA).
- If DNA is in water, add 8 µl of 5mM EDTA (pH 8.0) to the sample to bring the final volume to 40.0 µl.

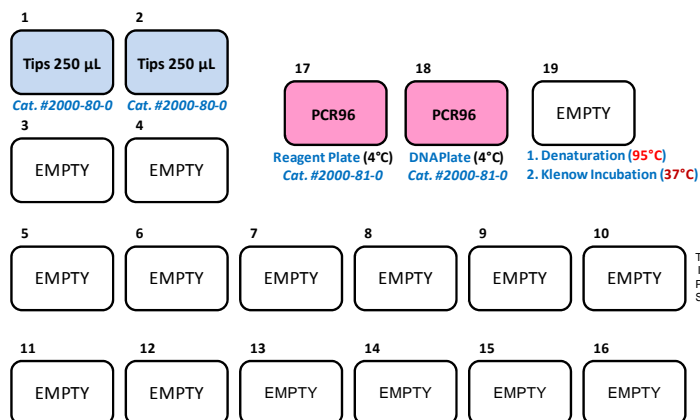

Figure 1. Deck layout for 12 labeling reactions.

### Instrument Setup for Labeling

- Ensure that all labware is placed correctly on the ArrayPrep® System (Figure 1). Remove tips from bottom two rows of tip racks in positions 1 & 2 (Figure 2). Place a container for used tips next to position 10 (Figure 3).
- Turn on main power to instrument.
- Switch on the three temperature controlled blocks. Set positions 17 and 18 to 4 °C. Set position 19 to 95 °C and connect a lid (Figure 3). Allow temperature to stabilize.
- Take a **NimbleGen Dual-Color DNA Labeling Kit** from the freezer and place vials on ice until thawed.
- Pipette 998.25 µl of Random Primer Buffer (vial 2) into a 1.5 ml reaction tube. Add 1.75 µl 2-Mercaptoethanol to a final volume of 1 ml.
- Briefly centrifuge Cy-3 and Cy-5 Random Nonamers (vials 3 & 4) and then add 495 µl of Random Primer Buffer with 2-Mercaptoethanol (prepared in step 5) to each vial.\*
- Prepare a dNTP/Klenow Master Mix by pipetting 122.5 µl 10mM dNTP Mix (vial 6), 98 µl nuclease-free water (vial 1) and 24.5 µl Klenow Fragment (3'->5' exo-), 50 U/µl (vial 5) into a 1.5 ml reaction tube.
- Pipette solutions from steps 6 and 7 into each well of the PCR reagent plate as follows:
  - 40 µl of diluted Cy-3-Random Nonamers into **column 1, A-F**.
  - 40 µl of diluted Cy-5-Random Nonamers into **column 2, A-F**.
  - 40 µl of dNTP/Klenow master mix into **column 3, A-F**.
- Place the reagent plate into position 17, pre-cooled to 4 °C.

\*Store remaining reagents at -20 °C, protected from light. Do not store diluted Random Nonamers longer than 4 months.



Figure 2. Remove tips.

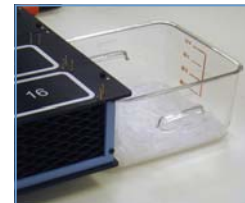

Figure 3. Used tips container.



Figure 4. Connect lid.

# Labeling and Purification of 12 Genomic DNA Samples for the NimbleGen Kit

## Set Up DNA Plate

1. Pipette DNA samples (1 µg / 40.0 µl TE) into each well of **column 1 (Cy3)** and **column 2 (Cy5)** of the 96-well PCR plate.
2. Place the DNA plate on block position 18 at 4 °C.

## Run Labeling Protocol

1. Launch the ArrayPrep® software by clicking the “ArrayPrep” icon on the desktop. Select File | Run Protocol. Go to folder “Desktop/ArrayPrep Protocols” and select the “12 rxns Genomic DNA Labeling\_NimbleGen” program. Press START.

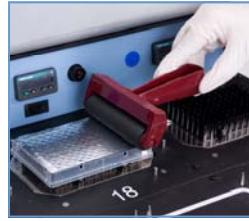

Figure 5. Roll film to ensure a good seal.

2. The instrument will dispense 40 µl of diluted Random Nanomers of Cy-3 to column 1 and Cy-5 to column 2 of the DNA plate and then pause. Seal the plate with PCR Plate Sealer (Figure 5) and place it in position 19 at 95 °C.



Figure 6. Place lid over block in position 19.



3. Using a timer, denature the DNA for 10 minutes at 95 °C. Cover the block with the preheated lid (Figure 6) to minimize condensation.

4. After denaturation, remove heated lid and move sample plate back to position 18 at 4 °C. Ensure foil is tightly sealing the plate. Cool samples for 5 minutes at 4 °C.
5. Lower the temperature of block at position 19 to 37 °C. Connect an unheated lid (Figure 4).

6. Remove the sample plate from position 18 and spin down any condensate for 30 seconds.

7. Return the sample plate to position 18 and unseal plate.
8. Press CONTINUE on the ArrayPrep® software to re-start the protocol. The instrument will dispense 20 µl of dNTP/ Klenow Master Mix to all DNA samples.



9. Seal the sample plate again, place in position 19 and cover with a lid preheated to 37 °C (Figure 6). Incubate samples for 2 hours at 37 °C.

10. After the labeling reaction is complete, spin plate for 30 seconds.

11. Return sample plate to position 18 at 4 °C and unseal plate. The labeled DNA is ready for purification.

— End Labeling Protocol —

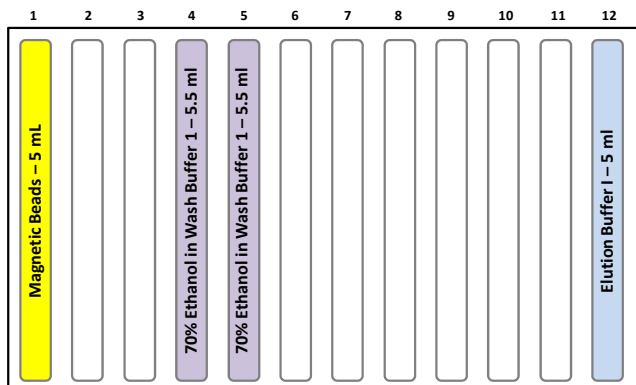

Figure 7. Magnetic Beads and Buffers for Purification.

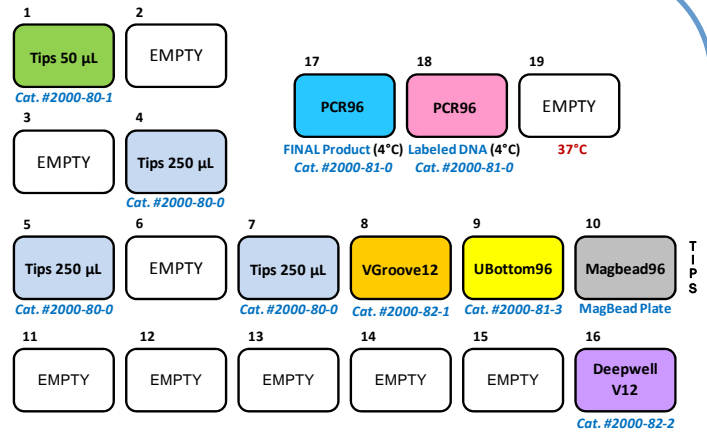

Figure 8. Deck layout for magnetic bead purification of 12 samples.

## Reagent Preparation for Purification

1. Allow magnetic beads stored at 4 °C to equilibrate to room temperature for at least 1 hour before starting the protocol.
2. Thoroughly shake the bottle with magnetic beads. Pipette 5 ml into column 1 of the V-Groove Reservoir (Figure 7).
3. Make a 70% Ethanol solution in Wash Buffer 1. Mix 10.5 ml of fresh 100% EtOH with 4.5 ml of Wash Buffer I. Add 5.5 ml into columns 4-5 of the V-Groove Reservoir.
4. Add 5 ml Elution Buffer I into column 12 of the V-Groove Reservoir.

## Run Purification Protocol

1. Ensure that all labware is placed on the correct positions on the ArrayPrep® instrument (Figure 8). Remove tips from bottom two rows of tip racks in positions 1, 4, 5 & 7, similar to Figure 2.
2. On the ArrayPrep® software, Select File | Run Protocol. Go to folder “Desktop/ArrayPrep Protocols” and select the “12 rxns Bead-based Purification\_NimbleGen” program. Press START.
3. Samples are automatically purified column by column. Magnetic beads are added, mixed thoroughly and unbound material is removed. Beads are washed twice with 70% Ethanol in Wash Buffer I, dried and 50 µl Elution Buffer I added. Purified labeled product in 50 µl Elution Buffer I is then transferred to the 96-well PCR plate on a cooling block at position 17. Samples are now ready for measuring yield, purity and dye incorporation.

— End Purification Protocol —

### IMPORTANT POINTS:

- Ensure correct placement of reagent plate on cooling block position 17.
- Use a pre-heated lid during incubation.
- Equilibrate magnetic beads to RT before use.
- Always prepare 70% Ethanol in Wash Buffer I fresh. Discard after use.

**SciGene**  
Automating Array Workflows

All third party marks are the property of their respective owners.